

ART. 224/A

1000 | **KG**

SOLLEVAMENTO MANUALE  
MANUAL LIFTING  
LEVAGE MANUEL  
MANUELLE ANHEBUNG



ART. 224/B

1000 | **KG**

SOLLEVAMENTO ELETTRIDRAULICO  
A BATTERIA  
BATTERY-POWERED  
ELECTRO-HYDRAULIC LIFTING  
LEVAGE ÉLECTROHYDRAULIQUE  
À BATTERIE  
ELEKTROHYDRAULISCHE ANHEBUNG  
IM BATTERIEBETRIEB



### TRACCIATO TECNICO COSTRUTTIVO

- Carrelli transpallet a pantografo professionali.
- L'altezza di sollevamento di quasi 1 metro li rende ideali per essere impiegati anche come piattaforma di lavoro.
- Timoniera ergonomica.
- Cilindro telescopico a due stadi.
- Steli in acciaio speciale rettificato e cromato.
- Valvola di discesa proporzionale per controllare la velocità di discesa a seconda della posizione della leva.
- Dotati di stabilizzatori anteriori e posteriori.
- Valvola di sicurezza contro i sovraccarichi.
- Rulli e ruote ricoperte in poliuretano (Art. 224/A)
- Rulli in poliuretano e ruote in gomma (Art. 224/B)

### TECHNICAL AND STRUCTURAL LAY-OUT

- Professional scissor pallet trucks.
- The lifting height of almost 1 meter makes them ideal for use as a work platform.
- Ergonomic steering.
- Two-stage telescopic cylinder.
- Stems in special ground and chromed steel.
- Proportional descent valve to control the descent speed depending on the position of the lever.
- Fitted with front and rear stabilizers
- Overload safety valve
- Polyurethane rollers and wheels (Art. 224/A)
- Polyurethane rollers and rubber wheels (Art. 224/B)

### RELEVÉ TECHNIQUE

- Transpalette haute levée professionnel
- Levage jusqu'à quasiment 1 m, parfait pour travailler à hauteur, vous pouvez l'utiliser aussi comme établi
- Poignée ergonomique
- Vérin télescopique
- Tige en acier chromé rectifié
- Contrôle de la vitesse de descente en fonction de la position du timon par vanne de descente proportionnelle
- Stabilisateurs à l'avant et à l'arrière
- Vanne de sécurité anti-surcharge
- Rouleaux et roues polyuréthane (Art. 224/A)
- Rouleaux polyuréthane et roues caoutchouc (Art. 224/B)

### TECHNISCHE UND KONSTRUKTIVE ANGABEN

- Professionelle Scherenhubwagen.
- Durch ihre Hubhöhe von fast einem Meter sind diese Wagen auch ideal als Arbeitsbühne geeignet.
- Ergonomische Lenkstange.
- Teleskopzylinder mit zwei Stufen.
- Geschliffene und verchromte Stangen aus Spezialstahl.
- Proportionales Absenkenventil zum Steuern der Absenkgeschwindigkeit je nach Hebelstellung.
- Vorn und hinten mit Stabilisatoren ausgerüstet.
- Sicherheitsventil gegen Überlastung.
- Rollen und Räder mit Beschichtung aus Polyurethan (Art. 224/A)
- Rollen aus Polyurethan und Räder aus Gummi (Art. 224/B)

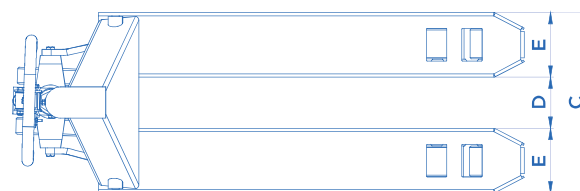
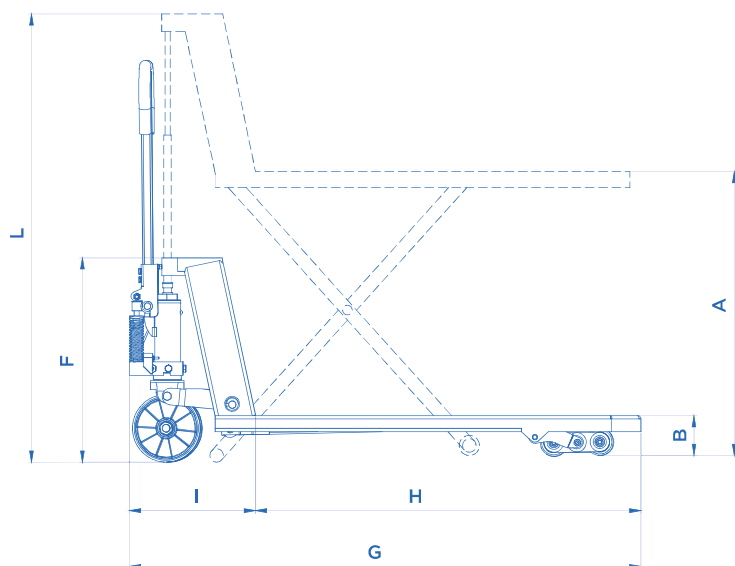

ART.		A mm	B mm	C mm	D mm	E mm	F mm	G mm	H mm	I mm	L mm	
224/A	1000 Kg	800	85	540	220	160	735	1545	1150	395	1285	110
224/B	1000 Kg	800	85	540	220	160	887	1665	1150	515	1244	150

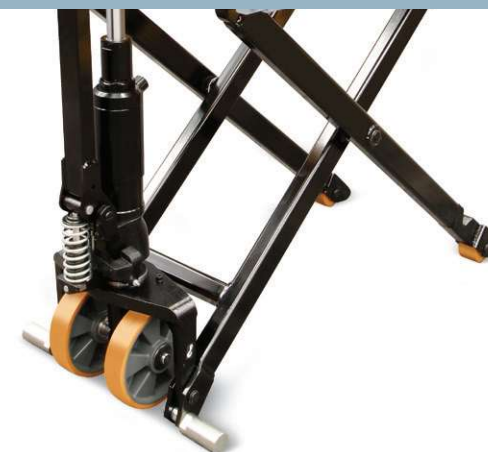

ART. 223/A



2500 KG

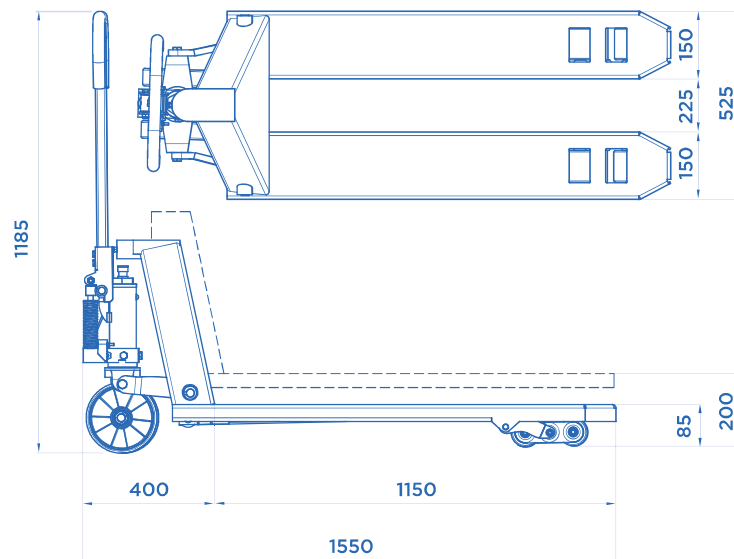

### TRACCIATO TECNICO COSTRUTTIVO

- Carrelli transpallet professionali.
- Robusta struttura sovradimensionata realizzata esclusivamente in acciaio.
- Finecorsa meccanico di sicurezza.
- Comando di discesa manuale.
- Leverismo anteriore in alluminio.
- Comando di discesa a velocità controllata "uomo presente".
- Valvola di sicurezza contro i sovraccarichi.
- Ruote posteriori in alluminio montate su cuscinetti.
- Doppie rulli anteriori in poliuretano.
- Ruote posteriori ricoperte in gomma.

### TECHNICAL AND STRUCTURAL LAY-OUT

- Professional forklifts.
- Sturdy oversized structure fully made of steel.
- Mechanical safety limit switch.
- Descent control by hand.
- Front linkage made of aluminium.
- "Man-standing by" descent control device with controlled speed.
- Safety valve to avoid any possible overload.
- Rear wheels made of aluminium, mounted on bearings.
- Double front rolls made of polyurethane.
- Rubber covered wheels.

### RELEVÉ TECHNIQUE

- Transpalettes professionnelles.
- Structure surdimensionnée très robuste réalisée exclusivement en acier.
- Fin course mécanique de sécurité.
- Commande de descente manuel.
- Barre de levage antérieure en aluminium.
- Commande de descente de type « homme-mort » à vitesse contrôlée.
- Soupape de sécurité anti-surcharge.
- Roues arrières en aluminium, montées sur roulement.
- Double rouleaux avant en polyuréthane.
- Roues arrières couverture caoutchouc.

### TECHNISCHE UND KONSTRUKTIVE ANGABEN

- Professioneller Palettenhubwagen.
- Überdimensionierte Struktur, die nur aus Stahl realisiert ist.
- Mechanischer Sicherheitsendschalter.
- Mit einer Manuelle Abstiegskontrolle.
- Vordere Hebestange aus Aluminium.
- Totmann -Abstiegskontrolle mit einer kontrollierten Geschwindigkeit.
- Überlastventil gegen jeder Überlastung.
- Hinterrädern aus Aluminium, die auf Lagern montiert sind.
- Doppelvorderrollen aus Polyurethan.
- Hinterrädern aus Gummi bedeckt.



223/A | 2500 Kg | 80