



ART. 3010



ART. 3000



## TRACCIATO TECNICO COSTRUTTIVO

- Design completamente innovativo.
- Punti presa super ribassati.
- Manico ergonomico.
- Supporto piattello a base ampia.
- Piattello in gomma.
- Ruote in nylon (Art. 3000).
- Dotato di ruote in poliuretano con doppi rulli basculanti anteriori (Art. 3010).
- Dotato di comando di discesa a pedale (Art. 3010).
- Dotato di comando di discesa manuale (Art. 3000).

## TECHNICAL AND STRUCTURAL LAY-OUT

- Completely innovative design.
- Very low profile.
- Ergonomic handle.
- Support holder with wide base.
- Rubber covered support.
- Nylon wheels (Art. 3000).
- Equipped with double frontal balancing rolls and rear turning wheels in polyurethane (Art. 3010).
- Foot descent-control (Art. 3010).
- Hand descent-control (Art. 3000).

## RELEVÉ TECHNIQUE

- Innovation du design.
- Points de prise surbaissés
- Manche ergonomique.
- Support plateau à base large.
- Plateau caoutchouc.
- Roues en nylon (Art. 3000).
- Avec roues avant en polyuréthane à double rouleaux à bascule (Art. 3010).
- Avec commande de descente à pied (Art. 3010).
- Avec commande de descente manuelle (Art. 3000).

## TECHNISCHE UND KONSTRUKTIVE ANGABEN

- Völlig innovatives Design.
- Super abgeflachte Aufnahmepunkte.
- Ergonomische Zugstang.
- Tellerstütz mit weiter Grundlage.
- Gummiteller.
- Nylonräder (Art. 3000).
- Mit polyurethan Rädern, von denen kippen doppelten Vorderrollen (Art. 3010).
- Mit Fußhebel Abstiegkontrolle (Art. 3010).
- Mit manueller Abstiegkontrolle (Art. 3000).

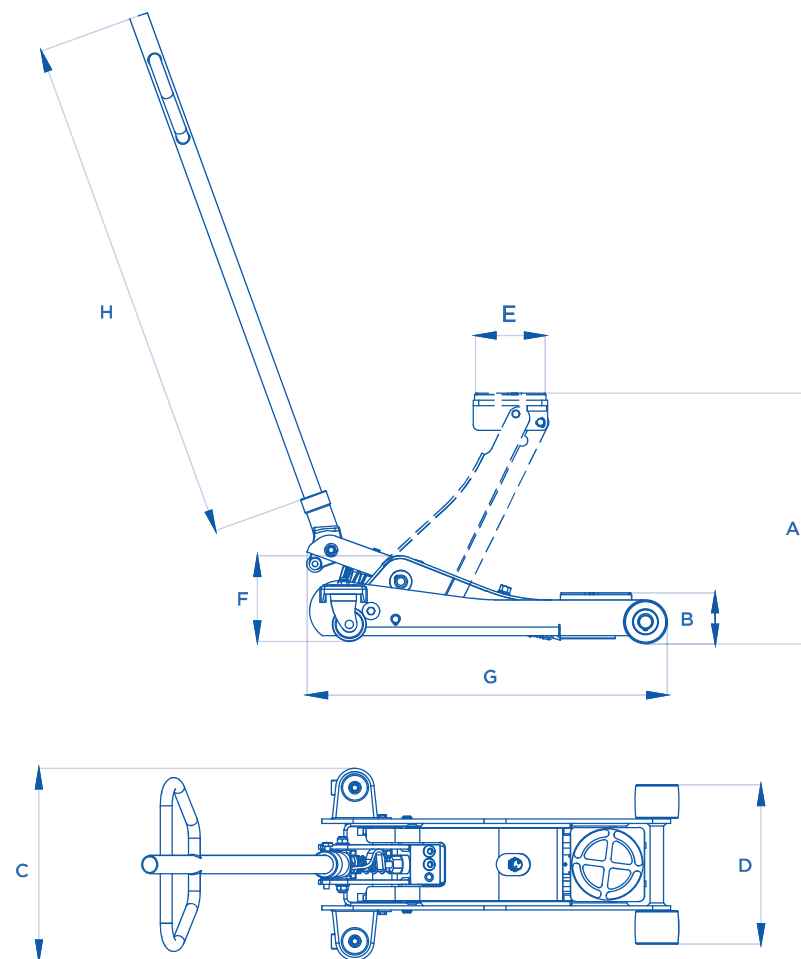

ART.		A mm	B mm	C mm	D mm	E mm	F mm	G mm	H mm	KG
<b>3000</b>	2000 kg	480	95	350	290	130	200	660	810	39
<b>3010</b>	2000 Kg	710	95	480	485	130	210	1000	780	67



ART. 3020

ART. 3030



## TRACCIATO TECNICO COSTRUTTIVO

- Design completamente innovativo.
- Punti presa super ribassati.
- Manico ergonomico.
- Supporto piattello a base ampia.
- Dotati di pedale di avvicinamento.
- Dotati di comando di discesa manuale.
- Piattello in gomma (Art. 3020).
- Piattello in acciaio (Art. 3030).
- Ruote in nylon.

## TECHNICAL AND STRUCTURAL LAY-OUT

- Completely innovative design.
- Very low profile.
- Ergonomic handle.
- Support holder with wide base.
- Equipped with foot-approaching control.
- Hand descent-control.
- Rubber covered support (Art. 3020).
- Stainless steel support (Art. 3030).
- Nylon wheels.





## RELEVÉ TECHNIQUE

- Innovation du design.
- Points de prise surbaissés.
- Manche ergonomique.
- Support plateau à base large.
- Avec pédale d'approche.
- Avec commande de descente manuelle.
- Plateau caoutchouc (Art. 3020).
- Plateau acier (Art. 3030).
- Roues en nylon.

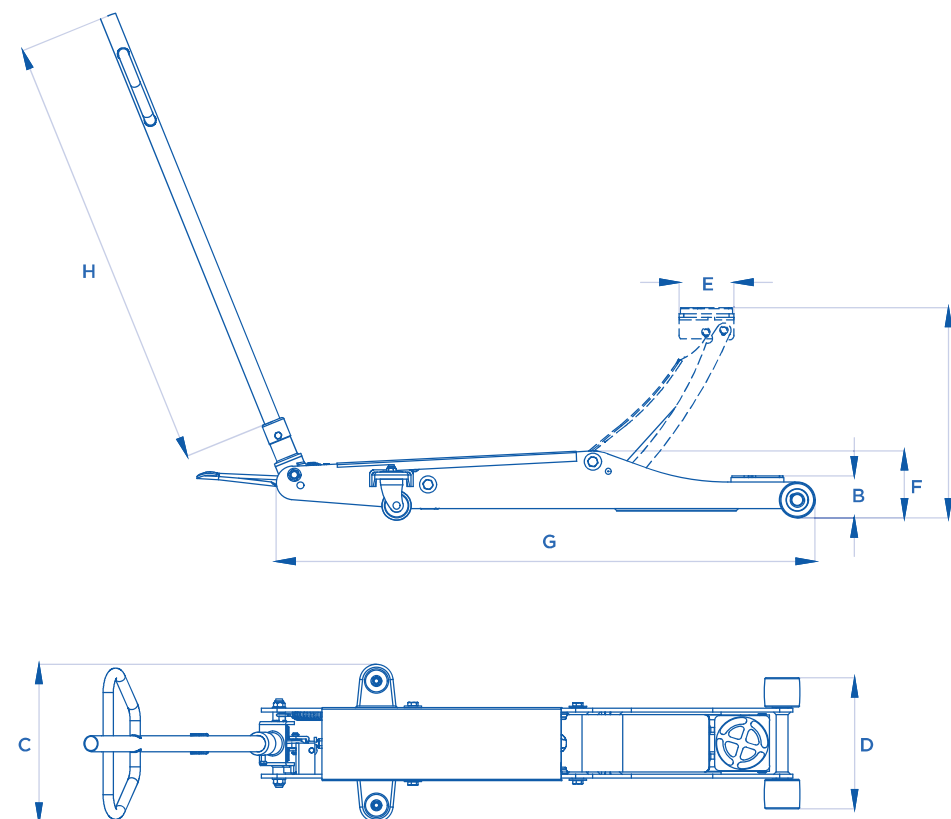
## TECHNISCHE UND KONSTRUKTIVE ANGABEN

- Völlig innovatives Design.
- Super abgeflachte Aufnahmepunkte.
- Ergonomische Zugstang.
- Tellerstütz mit weiter Grundlage.
- Anbewegung Fußhebel.
- Mit manueller Abstiegkontrolle.
- Gummiteller (Art. 3020).
- Stahlsteller (Art. 3030).
- Nylonräder.



ART.		A  mm	B  mm	C  mm	D  mm	E  mm	F  mm	G  mm	H  mm	 KG
<b>3020</b>	3000 kg	505	90	290	275	130	145	1260	915	52
<b>3030</b>	6000 Kg	555	130	370	290	130	185	1600	915	80

TOP  
LINE



ART. 3100IP

## TRACCIATO TECNICO COSTRUTTIVO

- Sollevatore oleopneumatico a carrello.
- Indicato per il sollevamento di autovetture, SUV, veicoli commerciali e industriali.
- Design completamente innovativo.
- Punto presa super ribassato.
- Manico ergonomico.
- Supporto piattello a base ampia.
- Ruote in nylon.

## TECHNICAL AND STRUCTURAL LAY-OUT

- Air-hydraulic trolley jack.
- Suggested to lift cars, SUV, commercial vehicles and medium lorries.
- Completely innovative design.
- Very low profile.
- Ergonomic handle.
- Support holder with wide base.
- Nylon wheels.

## RELEVÉ TECHNIQUE

- Cric rouleur oléopneumatique.
- Conseillé pour le levage de voitures, tout-terrains et poids moyens.
- Innovation du design.
- Point de prise surbaissé.
- Manche ergonomique.
- Support plateau à base large.
- Roues en nylon.

## TECHNISCHE UND KONSTRUKTIVE ANGABEN

- Hydropneumatischer Rangierheber.
- Bezeichnet für SUV, Fahrzeuge, Nutzfahrzeuge und medium LKW.
- Völlig innovatives Design.
- Super abgeflachte Aufnahmepunkte.
- Ergonomische Zugstang.
- Tellerstütz mit weiter Grundlage.
- Nylonräder.

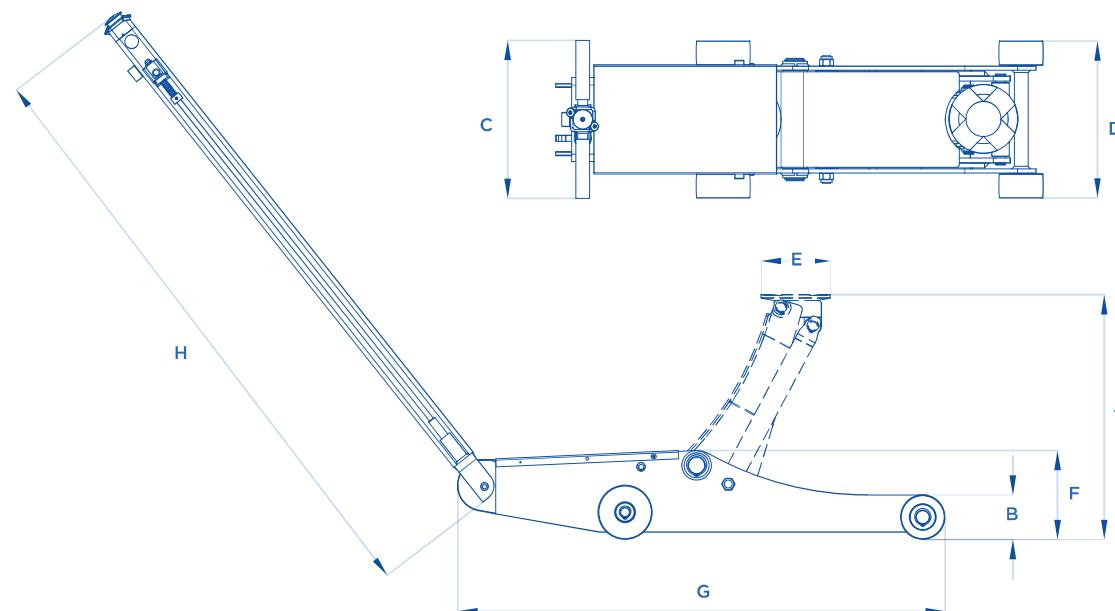

ART.			A mm	B mm	C mm	D mm	E mm	F mm	G mm	H mm	KG
3100IP	5000 kg	10 bar	500	90	320	320	140	180	970	1230	100

 Alimentazione pneumatica • Pneumatic feeding • Pression d'alimentation • Benötigter Luftdruck