

10•150
TON

W
LINE



ART. 164/W



ART. P30/W

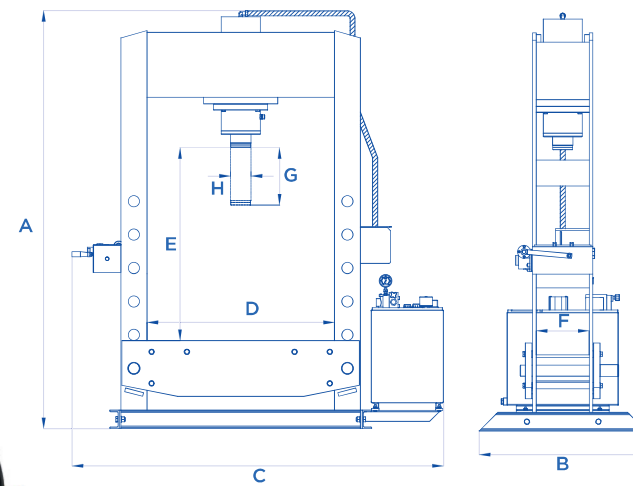

OPTIONAL Pag. 292



ART.	TON	 mm/min	 mm/min	 A mm	 B mm	 C mm	 D mm	 E mm	 F mm	 G mm	 H mm		
154/W	10	570		1920	500	1140	510	1010	140	260	40	1,5 kw	174
156/W	20	450		1950	500	1140	510	1010	140	285	50	1,5 kw	200
P30/W	30	575		2020	600	1700	695	1000	170	260	60	3 kw	330
162/W	50	600	215	2130	850	1650	775	1135	205	260	60	1,5 kw	530
163/W	70	595	260	2210	900	1755	880	1120	265	310	90	3 kw	800
164/W	100	570	180	2310	900	1930	1010	1055	280	310	110	3 kw	1050
164/WS	100	570	180	2470	1300	2320	1520	1065	360	310	110	3 kw	1500
204/W	150	600	120	2600	1300	2470	1520	1018	410	400	140	4 kw	2200
204/WE	150	600	120	2600	1300	1970	1020	1035	410	400	140	4 kw	1870

 Potenza motore • Motor power • Puissance moteur • Motorleistung  Velocità lavoro • Working speed • Vitesse travail • Arbeitsgeschwindigkeit

 Velocità avvicinamento • Approaching speed • Vitesse approche • Vorlaufgeschwindigkeit

TRACCIATO TECNICO COSTRUTTIVO

- Stelo del cilindro in acciaio speciale, trattato e cromato.
- Centralina motorizzata a due velocità ad inserimento automatico (escluso 154/W - 156/W - P30/W).
- **Azionamento tramite distributore a leva a 3 posizioni. Questa soluzione permette di avere una mano libera per lavorare.**
- Dotate di valvola di taratura per regolare la potenza in base alla lavorazione da eseguire.
- Massima versatilità grazie al bancale ad altezza regolabile.
- Sollevamento del bancale tramite apposito organo (P30/W - 162/W - 163/W - 164/W).
- Sollevamento del bancale tramite asta (164/WS - 204/W - 204/WE).
- Manometro fornito di serie.

TECHNICAL AND STRUCTURAL LAY-OUT

- Shaft of the cylinder made of treated and chromium-plated special steel.
- Motorized 2-speeds control unit with automatic insertion (except art. 154/W - 156/W - P30/W).
- **Start-up by means of a 3-position lever distributor. This solution allows you to have one hand free to work.**
- With a control valve to set the power according to the work you have to do.
- Maximum versatility thanks to the height-adjustable table.
- Winch to raise easily and quickly the workbench (P30/W - 162/W - 163/W - 164/W).
- Rod to raise the workbench (164/WS - 204/W - 204/WE).
- Supplied with a manometer.

RELEVÉ TECHNIQUE

- Tige du cylindre en acier spécial traité et chromé.
- Groupe hydraulique motorisé à deux vitesses à insertion automatique (sauf pour les art. 154/W - 156/W - P30/W).
- **Actionnement par distributeur à levier à 3 positions. Cette solution permet d'avoir une main libre pour travailler.**
- Soupape de calibrage pour régler la puissance par rapport au travail à faire.
- Ultra polyvalente grâce au plan de travail réglable en hauteur.
- Relevage du plan de travail par treuil (P30/W - 162/W - 163/W - 164/W).
- Relevage du plan de travail par barre (164/WS - 204/W - 204/WE).
- Manomètre de série.

TECHNISCHE UND KONSTRUKTIVE ANGABEN

- Zylinderkolben aus speziellen Stahl, behandelt sowie auch verchromt.
- Zweistufiges motorisiertes Steuergerät mit automatischen Einstecken (nicht für Art. 154/W - 156/W - P30/W).
- **Antrieb mittels einem Hebel-Dreiwegeverteiler. Diese Lösung erlaubt Sie einem Freihand zu haben, um zu arbeiten.**
- Mit einem Eichventil, um die Kraft der gemäß die Arbeitstypologie zu regeln.
- Maximale Vielseitigkeit dank dem höhenverstellbaren Tisch.
- Hebung dem Tisch mittels einer Winde (P30/W - 162/W - 163/W - 164/W).
- Hebung dem Tisch mittels einer Stange (164/WS - 204/W - 204/WE).
- Serienmäßiger Manometer.

**10•150
TON**

**R
LINE**

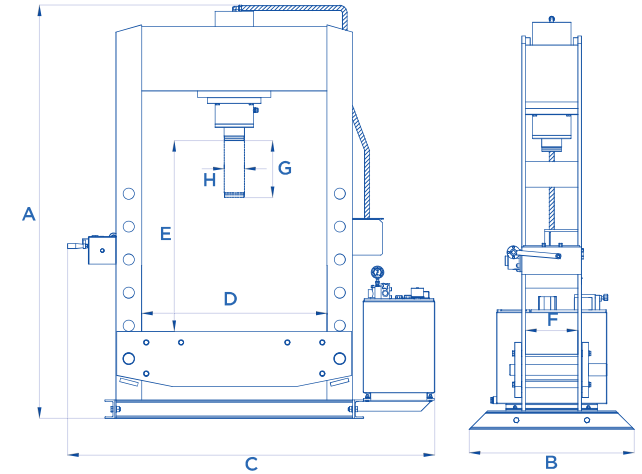
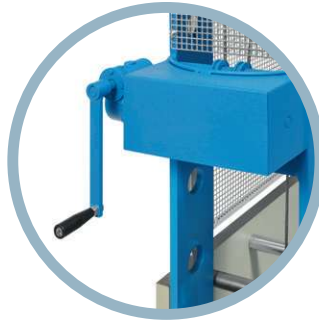

ART. 204/R

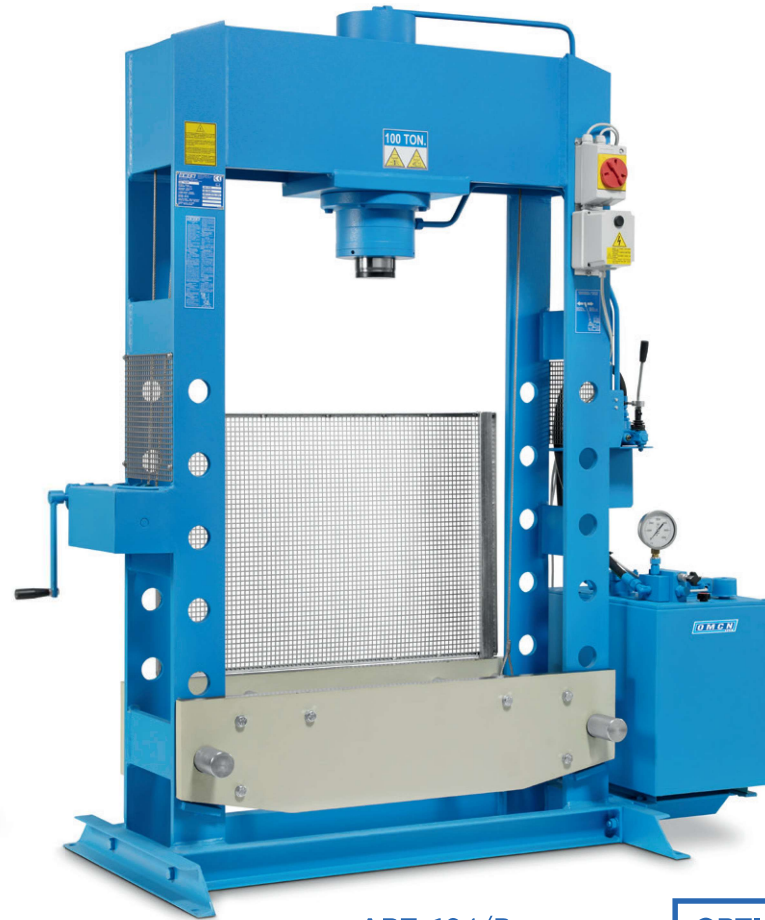

ART. 164/R

OPTIONAL Pag. 292



ART.	TON	mm/min	mm/min	mm	mm	mm	mm	mm	mm	mm	mm		
154/MR	10	1750	350	1920	500	1140	510	1010	140	260	40	0,75 kw	194
156/MR	20	1100	300	1950	500	1140	510	1010	140	285	50	0,75 kw	208
P30/MR	30	1550	300	2020	600	1700	695	1000	170	260	60	1,5 kw	338
162/R	50	1540	210	2130	850	1650	775	1135	205	260	60	1,5 kw	560
163/R	70	1600	260	2210	900	1755	880	1120	265	310	90	3 kw	850
164/R	100	1600	180	2310	900	1930	1010	1055	280	310	110	3 kw	1100
164/RS	100	1600	180	2470	1300	2320	1520	1065	360	310	110	3 kw	1500
204/R	150	1600	120	2600	1300	2470	1520	1018	410	400	140	4 kw	2200
204/RE	150	1600	120	2600	1300	1970	1020	1035	410	400	140	4 kw	1870

- Potenza motore • Motor power • Puissance moteur • Motorleistung Velocità lavoro • Working speed • Vitesse travail • Arbeitsgeschwindigkeit
- Velocità avvicinamento • Approaching speed • Vitesse approche • Vorlaufgeschwindigkeit

TRACCIATO TECNICO COSTRUTTIVO

- Stelo del cilindro in acciaio speciale, trattato e cromato.
- Centralina motorizzata a due velocità ad inserimento automatico.
- **Funzionamento tramite distributore a leva e pulsante sul quadro da azionare contemporaneamente.**
- Complete di pannelli protettivi posteriore e laterali in acciaio zincato.
- Dotate di valvola di taratura per regolare la potenza in base alla lavorazione da eseguire.
- Massima versatilità grazie al bancale ad altezza regolabile.
- Sollevamento del bancale tramite apposito argano (P30/MR - 162/R - 163/R - 164/R).
- Sollevamento del bancale tramite asta (164/RS - 204/R - 204/RE).
- Manometro fornito di serie.

TECHNICAL AND STRUCTURAL LAY-OUT

- Shaft of the cylinder made of treated and chromium-plated special steel.
- Motorized 2-speeds control unit with automatic insertion.
- **Operated by lever distributor and button on the control box to be activated simultaneously.**
- Protection rear and side panels made of zinc-plated steel.
- Calibrating valve to control the power according to the work you have to do.
- Maximum versatility thanks to the height-adjustable table.
- Winch to raise workbench (P30/MR - 162/R - 163/R - 164/R).
- Shaft to raise workbench (164/RS - 204/R - 204/RE).
- Supplied with standard manometer.

RELEVÉ TECHNIQUE

- Tige du cylindre en acier spécial traité et chromé.
- Groupe hydraulique de commande motorisé à deux vitesses à insertion automatique.
- **Fonctionnement par distributeur à levier et bouton sur le boîtier électrique à activer en simultanée.**
- Panneaux de protection arrière et sur les côtés en acier galvanisé.
- Soupape de calibrage pour régler la puissance par rapport au travail à faire.
- Ultra polyvalence grâce au plan de travail réglable en hauteur.
- Relevage du plan de travail par treuil (P30/MR - 162/R - 163/R - 164/R).
- Relevage du plan de travail par barre (164/RS - 204/R - 204/RE).
- Manomètre de série.

TECHNISCHE UND KONSTRUKTIVE ANGABEN

- Zylinderkolben aus speziellen Stahl, behandelt sowie auch verchromt.
- Zweistufiges motorisiertes Steuergerät mit automatischen Einstecken.
- **Betrieb mittels einem Hebelverteiler und einem Druckknopf auf die Schaltkaste, die gleichseitig geschaltet sein müssen.**
- Mit hinter- und seitlich Schutztafel aus verzinktem Stahl.
- Mit einem Eichventil, um die Kraft der Maschine gemäß die Arbeitstypologie zu regeln.
- Maximale Vielseitigkeit dank dem höhenverstellbaren Tisch.
- Hebung dem Tisch mittels einer Winde (P30/MR - 162/R - 163/R - 164/R).
- Hebung dem Tisch mittels einer Stange (164/RS - 204/R - 204/RE).
- Serienmäßiger Manometer.

200•300 TON

HEAVY DUTY

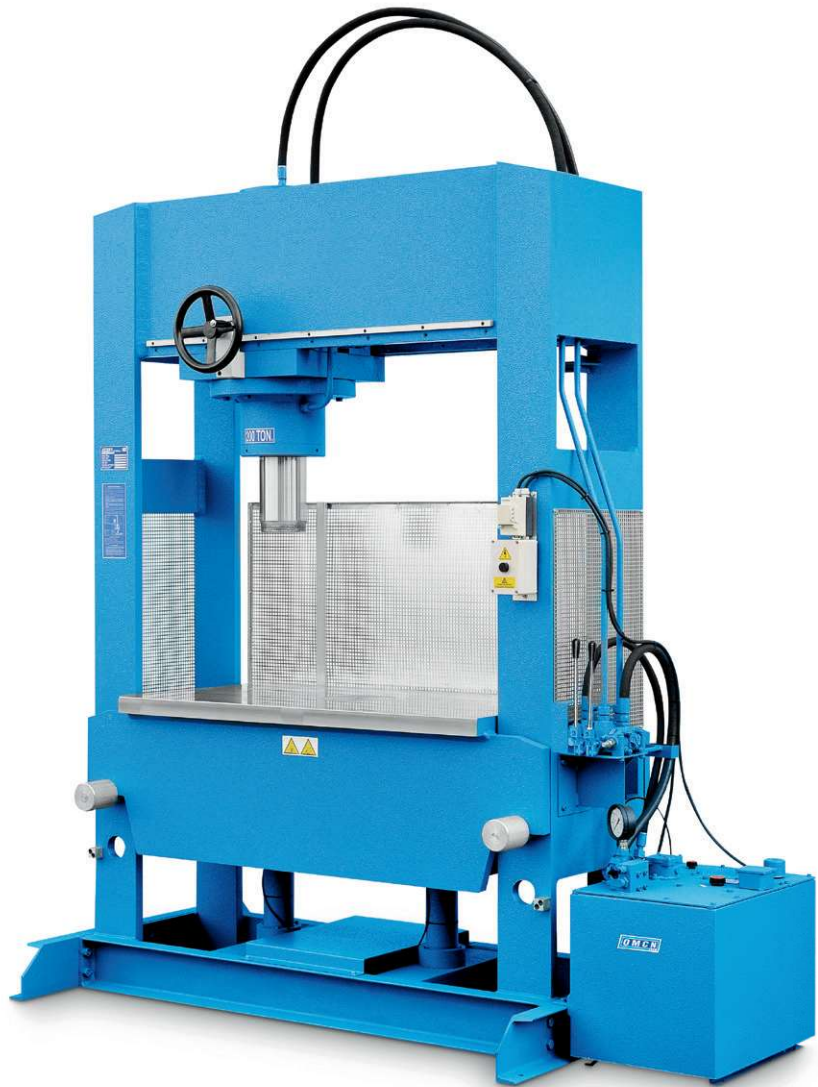

ART. 205/R+022/C

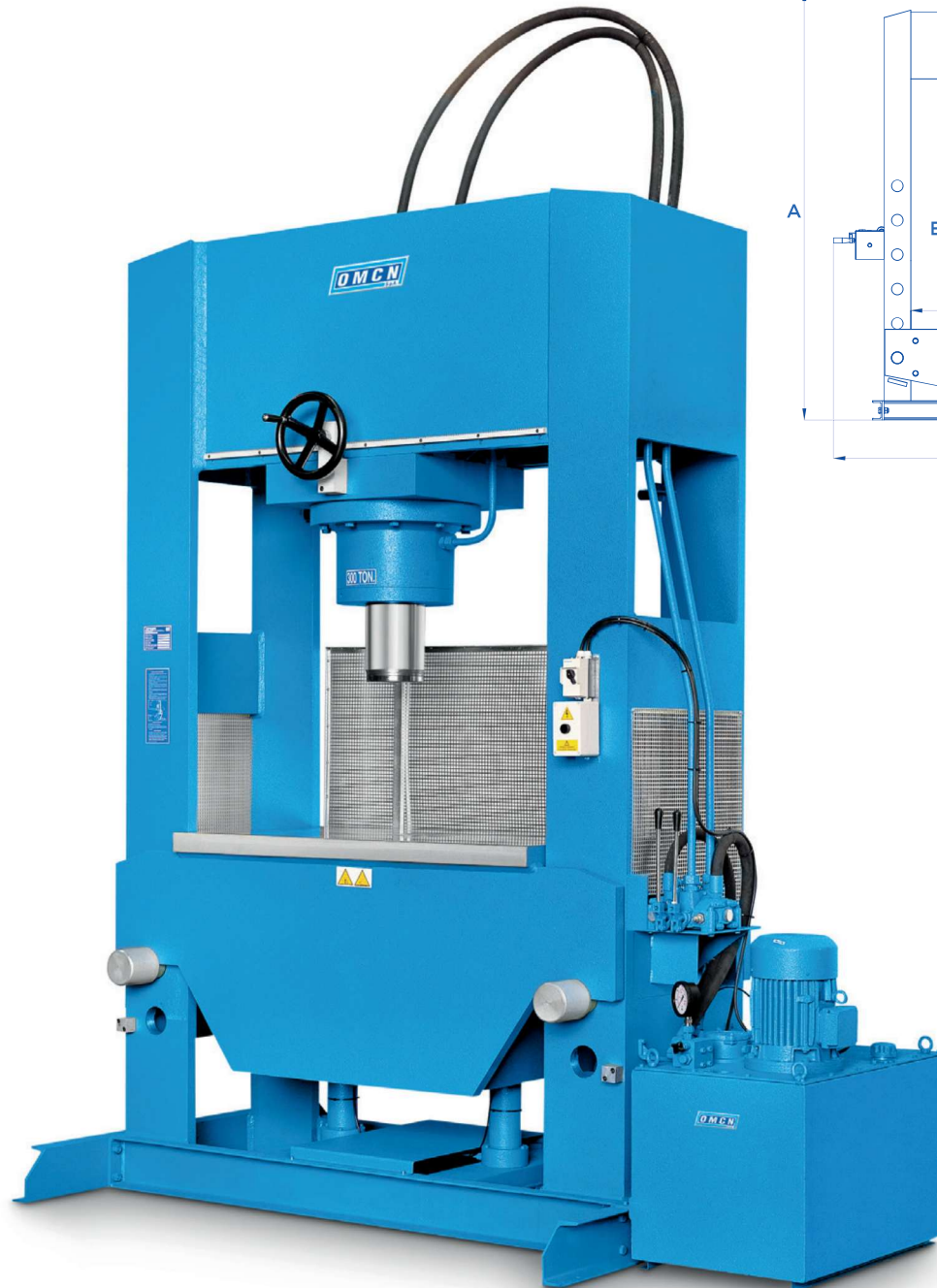

ART. 280/R+022/D

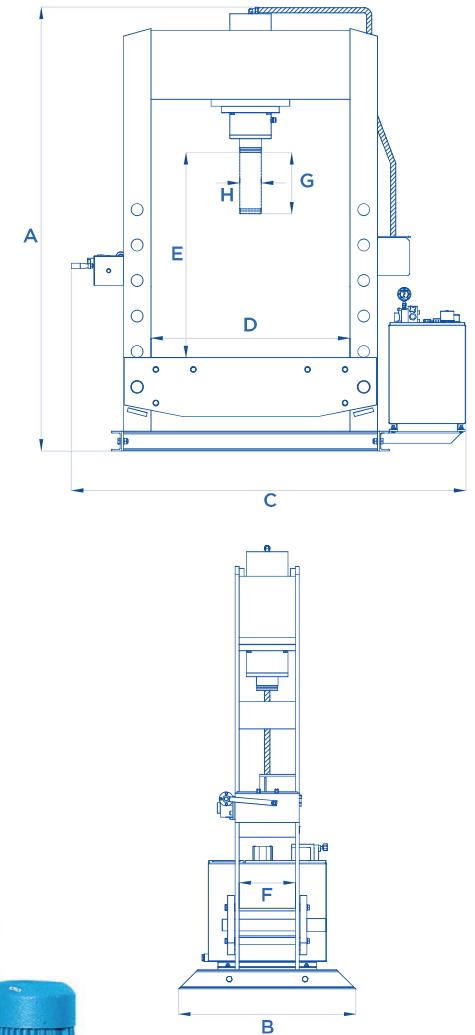

OPTIONAL Pag. 292

ART.	TON	 mm/min	 mm/min	 mm	 mm	 mm	 mm	 mm	 mm	 mm	 mm	 4 kw	 4150
205/R	200	1300	95	2995	1310	2600	1520	1020	520	520	170	4 kw	4150
205/W	200	600	95	2995	1310	2600	1520	1020	520	520	170	4 kw	4150
280/R	300	1000	95	3415	1700	2900	1500	960	640	500	210	5,5 kw	8200
280/W	300	600	95	3415	1700	2900	1500	960	640	500	210	5,5 kw	8200

 Potenza motore • Motor power • Puissance moteur • Motorleistung  Velocità lavoro • Working speed • Vitesse travail • Arbeitsgeschwindigkeit
 Velocità avvicinamento • Approaching speed • Vitesse approche • Vorlaufgeschwindigkeit

TRACCIATO TECNICO COSTRUTTIVO

- Stelo del cilindro in acciaio speciale, trattato e cromato.
- Centralina motorizzata a due velocità ad inserimento automatico.
- Funzionamento tramite distributore a leva e pulsante sul quadro da azionare contemporaneamente (205/R - 280/R).
- Azionamento tramite distributore a leva a 3 posizioni. Questa soluzione permette di avere una mano libera per lavorare (205/W - 280/W).
- Complete di pannelli protettivi posteriore e laterali in acciaio zincato (205/R - 280/R).
- Dotate di valvola di taratura per regolare la potenza in base alla lavorazione da eseguire.
- **Sollevamento del bancale tramite due cilindri idraulici azionabili tramite apposita leva.**
- Complete di piano di lavoro fresato.

TECHNICAL AND STRUCTURAL LAY-OUT

- Shafts of treated and chromium-plated special steel.
- Motorized 2-speeds control unit with automatic insertion.
- Operation by lever distributor and a button on the control box to be activated simultaneously (205/R - 280/R).
- Start-up by means of a 3-position lever distributor. This solution allows you to have one hand free to work (205/W - 280/W).
- Protection rear and lateral panels made of zinc-plated steel (205/R - 280/R).
- Calibrating valve to set the power according to the work you have to do.
- **Two hydraulic cylinders operated by a lever to raise the workbench.**
- Supplied with a milled working-table.

RELEVÉ TECHNIQUE

- Tige du cylindre en acier spécial traité et chromé.
- Groupe hydraulique motorisé à deux vitesses à insertion automatique.
- Fonctionnement par distributeur à levier et bouton sur le cadre à activer en simultanée (205/R - 280/R).
- Actionnement par distributeur à levier à 3 positions. Cette solution permet d'avoir une main libre pendant le travail (205/W - 280/W).
- Panneaux de protection arrière et sur les côtés en acier galvanisé (205/R - 280/R).
- Soupape de calibrage pour régler la puissance par rapport au travail à faire.
- **Relevage du plan de travail au moyen de deux vérins hydrauliques actionnés par levier.**
- Livré avec un plateau fraisé.

TECHNISCHE UND KONSTRUKTIVE ANGABEN

- Zylinderkolben aus speziellen Stahl, behandelt sowie auch verchromt.
- Zweistufiges motorisiertes Steuergerät mit automatischen Einstecken.
- Betrieb mittels einem Hebelverteiler und einem Druckknopf auf die Schaltkaste, die gleichzeitig geschaltet sein müssen (205/R - 280/R).
- Antrieb mittels einem Hebel-Dreiwegeverteiler.
- Diese Lösung erlaubt Sie einem Freihand zu haben, um zu arbeiten (205/W - 280/W).
- Mit hinter- und seitlich Schutztafel aus verzinktem Stahl (205/R - 280/R).
- Mit einem Eichventil, um die Kraft der Maschine gemäß die Arbeitstypologie zu regeln.
- **Hebung dem Tisch mittels zwei hydraulischer Zylindern, die mittels des geeigneten Hebels schaltbar sind.**
- Mit einem gefrästem Tisch