

POWER 76 HC



DESCRIZIONE

Portata massima 100 kg.
Rotazione con motore a corrente continua.
Inclinazione manuale.



DESCRIPTION

Maximum load 100 kg.
Slewing by DC motor.
Manual tilt.



DESCRIPTION

Portée max 100 kg.
Rotation avec moteur à courant continu.
Inclinaison manuelle.



BESCHREIBUNG

Maximale Tragfähigkeit 100 kg.
Rotation mit Gleichstrommotor.
Kippung manuell.



DESCRIPCIÓN

Capacidad máxima 100 kg.
Rotación por motor de corriente continua.
Inclinación manual.

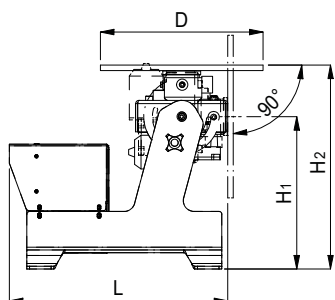
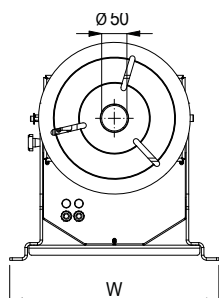

TIPO MOTORE	L MM	W MM	H1 MM	H2 MM	D mm	Power supply -volt	rpm	Portata / Load / Portee / Tragkraft / Capacidad		KG
								Horizontal kg	Vertical kg	
DC	450	414	281	378	300	1 PH - 230	0,6-6	100	50	26