

CARRELLI DI TRASPORTO CON TIMONE E RALLA MOVING TROLLEY

Tipo Type	Altezza supporto Height of support plate MM.	Diametro ralla rotante Rotating plate surface diam MM.	Lunghezza manico Length of pulling bar MM.	Base d'appoggio Base dimension MM.	Base d'appoggio carrello ausiliario Rear adjustable cart MM.	Peso carrello Weight of the trolley KG.	Peso carrello ausiliario Weight of the rear adjustable cart KG.	Portata Capacity TON.
Art. 106	110	170	1000	540 x 500 h. 115	Art. 106/A 110 x 310 h. 110	28	16	8
Art. 107	110	170	1000	680 x 500 h. 115	Art. 107/A 200 x 315 h. 110	35	30	16

Nuovi carrelli per la movimentazione di carichi pesanti ed eccezionali in modo semplice e sicuro.

Struttura solida e robusta realizzata in acciaio elettrosaldato garantisce stabilità in tutte le situazioni di lavoro.

Realizzati con cassette oscillanti e basculanti, che assicurano una estrema versatilità e manovrabilità del carico.



Mod. 106/A

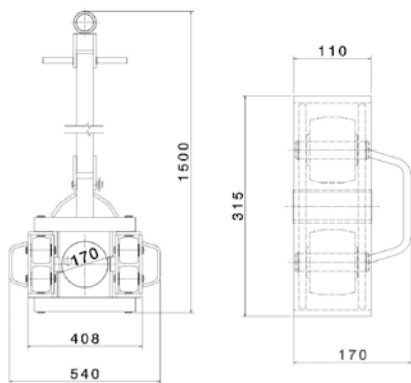
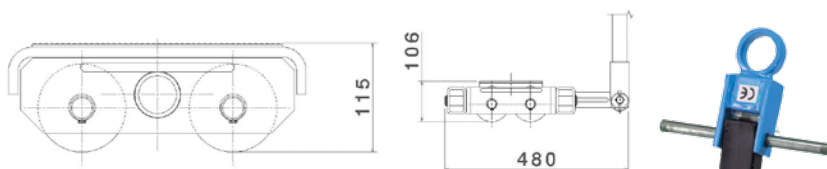

Mod. 106



Mod. 107/A

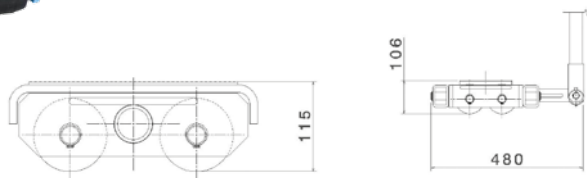

Grazie infatti alla ralla oscillante di 360 gradi, è possibile movimentare carichi importanti con estrema semplicità e sicurezza. Un corretto uso degli spazi ha fatto in modo di avere un peso molto contenuto.

Componibili tra loro, a richiesta è possibile avere anche manici più lunghi. I rulli sono costruiti in una nuova miscela antigraffio ed antiurto in nylon + gomma. **Assemblati a mano.**

New special trolley for moving safely heavy load. Solid and strong structure made of steel, guarantee stability in all the correcting operation position. Thanks to the 360° rotating plate, guarantees easy movement of the load. Developed with a new combined support wheels assure better moving performances and can be used combined with themselves.

*The wheels are made with a new type of nylon + rubber. **Hand assembled.***

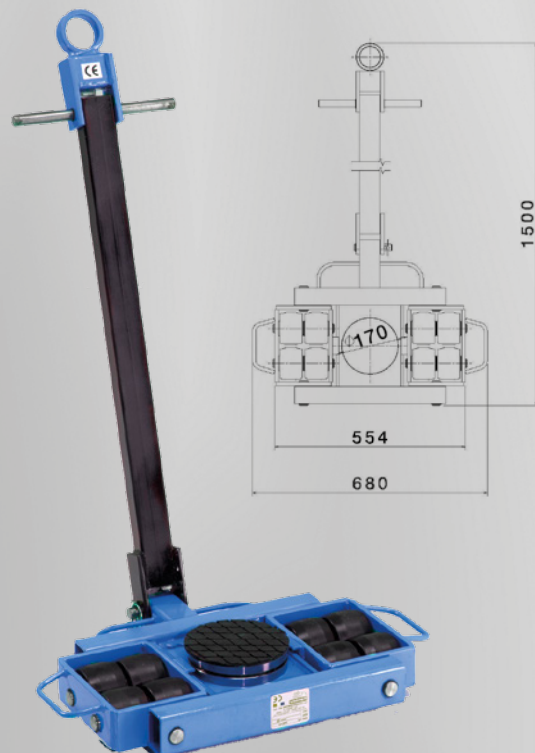

Mod. 107

